

TRACENET™ GENESIS

CONTROL AND MONITORING SYSTEM

SPECIFICATION GUIDE



APPLICATION OVERVIEW

Control and monitoring systems can play an essential role in heat tracing applications which range from freeze protecting water lines to maintaining elevated process temperatures. While mechanical thermostats have been used successfully for many heat tracing applications, a more complete control and monitoring solution can be necessary for critical heat tracing applications. Advancements in technology have made electronic control and monitoring units both cost effective and more reliable. These systems conserve energy, extend system life, and ensure accurate temperatures are maintained, for reduced operating cost and increased plant reliability.

TraceNet Genesis' key features include:

- Monitor electric heat trace circuit load currents
- Selectable control methods (On/Off, On/Off with Soft Start, Proportional, Ambient Proportional) for each individual circuit
- Programmable alarm set points, with time delay and remote alarm acknowledgment and reset capabilities
- Programmable "trip" set-points for each circuit
- Temperature sensor status indication
- Unique circuit identifier (48 characters maximum)
- Communication to host computer via Ethernet communications
- Adjustable ground/earth leakage "trip" and/or alarm capabilities
- Addressable RTD Temperature Sensors- up to 20per circuit
- Up to 6 months history to aid in troubleshooting
- ISO drawing in png format for viewing on Genesis HMI

GENESIS SYSTEM APPROVALS



Nonhazardous Locations
ETL Listed Conforms to: UL STD. 508A
Certified to: CSA STD. C22.2 NO. 14



Hazardous Locations (Purge)
ETL Listed Conforms to: UL STD. 508A. NFPA STD. 496
Certified to: CSA STD. C22.2 NO. 14



Hazardous Locations
ETL Listed Conforms to: UL STD. 508A. UL STD. 12.12.01
Certified to: CSA STD. C22.2 NO. 14. CSA STD. C22.2 NO. 213

¹ System approval requires panel to be fabricated at corporate headquarters.

GENESIS COMPONENT APPROVALS

TraceNet systems are certified for nonhazardous locations, hazardous locations, and Purge for hazardous locations

IEC/EN/UL/CSA 61010-1

Ex ec IIC T4 Gc; II 3 Ex ec IIC T4 Gc

Class I, Division 2, Groups ABCD T4; Class I, Zone 2 Group IIC T4



TRACENET GENESIS PANEL

SYSTEM SPECIFICATIONS (Based on lowest rating of all components)

Environmental:

Hazardous and Ordinary Locations

- Indoor and Outdoor-Solid State Relays

Ordinary Locations

- Indoor and Outdoor- Power Distribution and Mechanical Relays

Operating Ambient Range: -40°C to 60°C

Enclosures: Type 4X, IP 66 *

TraceNet Supply Voltage: 100-240 Vac, 50/60 Hz

Heat Tracing Voltages: 100-600 Vac

User Interface: 231 mm x 139 mm LVDS TFT LCD glove touch panel

Maximum Number of Circuits: Seventy-two (72)

Temperature Sensors per Circuit: Up to twenty (20) 100 Ω Platinum, 3 wire RTD's

Current Switching Device Options:

Solid State Relay **

1-pole

2-pole

Mechanical Relay:

Per design requirements

Control Methods:

Process Sensing:

On/Off, On/Off Soft Start, Proportional

Ambient Sensing:

Proportional, Ambient Proportional-Mechanical (APCM), APC

Control Temperature Range: -129°C to 600°C

Alarm Settings:

Low, High Temperature, and High Temperature Trip

Low, High Current, and High Current Trip

High Ground/Earth Leakage Current

RTD and Relay Faults

Loss of Communication

Programming Error

Trip Settings:

High Temperature, Heater Current, Ground or Earth

Leakage Current

Networking Communications:

External: Ethernet

External Alarm Relays:

Up to seven mechanical, 6 A @ 250 Vac or Vdc

* Additional cabinet types are available. Contact Thermon for details.

** Rating based on extended heat sinks. Multiple single pole relays may be used for two and three phase circuits. Higher voltage rated relays are also available as an option.

HMI (HUMAN MACHINE INTERFACE)

The HMI serves as the central monitoring and interrogation point for a TraceNet™ Genesis system, including its heat tracing control modules. Through its touch screen monitor, the HMI allows the operator to access operating control parameters and operating conditions throughout the heat tracing system network.

The HMI communicates directly with TraceNet Command and DCS systems through its Ethernet port.

HMI SPECIFICATIONS

Operating supply voltage.....	24 Vdc
Max Power consumption.....	30 Watts
Clock speed.....	1.5 GHZ
Processor.....	32 Bit Arm Cortex A15
IP Rating.....	Type 4X, IP66
Brightness.....	1000 cd/m ²
Input/Output ports.....	Ethernet/USB
Maximum storage temperature.....	85°C
Minimum storage temperature.....	-40°C
Operating ambient temperature range.....	-40°C to 70°C

HMI DIMENSIONAL DATA



Circuit History For Trending



Circuit Dashboard



Circuit Isometric Drawing



"Glove Touch" User Interface

HMI PRODUCT FEATURES

- TraceNet Genesis HMI Is IP66
- Module operates in a wide range of ambient conditions
- Multi-language capability
- Color display utilizes LED backlighting to maximize service life and is additionally programmable for “sleep mode” operation
- Utilizes projected capacitive touch screen for user input functions
- Intuitive user friendly graphical interface
- Type 4X, IP66 panel mount enclosure which may be installed on panel with access door or inside on panel swingout
- Optically bonded display for bright sunlight visibility

DCM (DISTRIBUTED CONTROL MODULE)

The DCM serves as the power switching module, using solid state relays for a TraceNet™ network of heat tracing control modules.

DCM FEATURES

- Operates in a wide range of ambient conditions
- Single or dual pole solid state switching
- Nickel plated terminal construction
- Black anodized aluminum heat sink capable of dissipating the heat generated for up to a total of 180 Amps continuous
- Includes a ground/earth leakage circuit test loop which allows the operator to conduct a functionality test on each circuit
- The DCM module has the following control modes:
 1. On-Off
 2. On-Off with Soft-Start (solid state relays only)
 3. Proportional (solid state relays only)
 4. Ambient Proportional (solid state relays only)
 5. Ambient Proportional- Mechanical
- Activates test functions including:
 1. Ground/Earth Leakage Fault Circuit Test
 2. Loss of Heater Current Test
- Activates programmed control function based on the temperature values provided by up to 20 RTD's per circuit
- Monitors ground/earth leakage and heater operating current in heat tracing circuits

DCM CONNECTION DIAGRAM

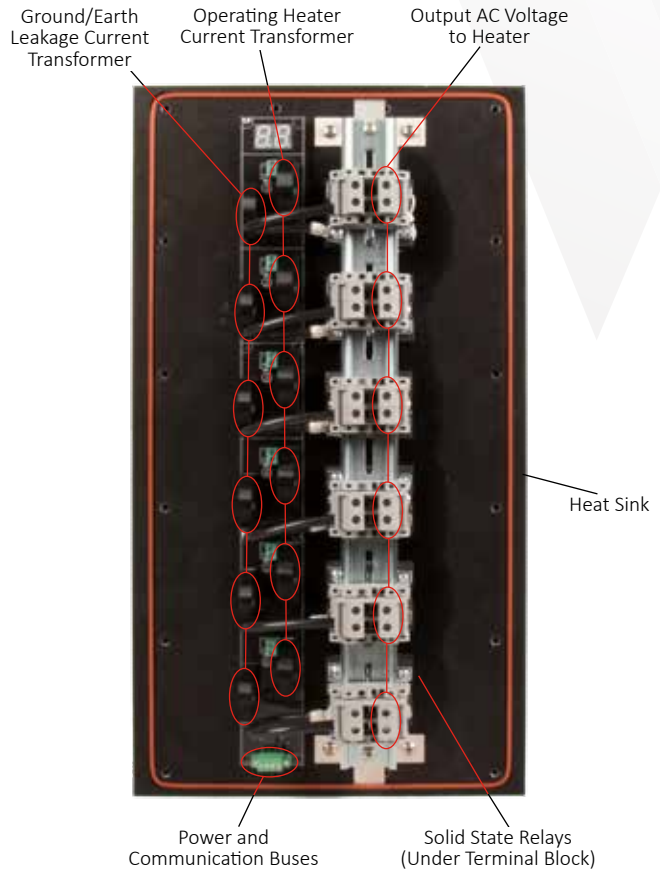

DCM COMPONENT SPECIFICATIONS

Circuit control capacity up to six heat trace circuits
 Storage ambient temp. range -40°C to 105°C
 Operating ambient temp. range -40°C to 100°C
 Power terminal connections¹
 0.5 to 10 mm², 630 Vac
 Printed circuit board conformal coated
 Heat sink Type 4X, IP66

1. DIN-rail mounted terminal blocks for line voltage to be off PC board.

DCM DIMENSIONAL DATA

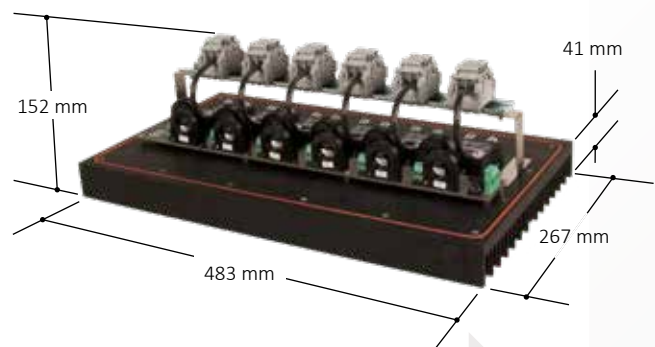

DTM (DISTRIBUTED TEMPERATURE MODULE)

The DTM is a DIN rail mountable six RTD sensor input module which links the field RTD wiring to the DCM module via CANBus. Any RTD sensor may be mapped to any heater circuit on the CANBus network.

DTM DIMENSIONAL DATA

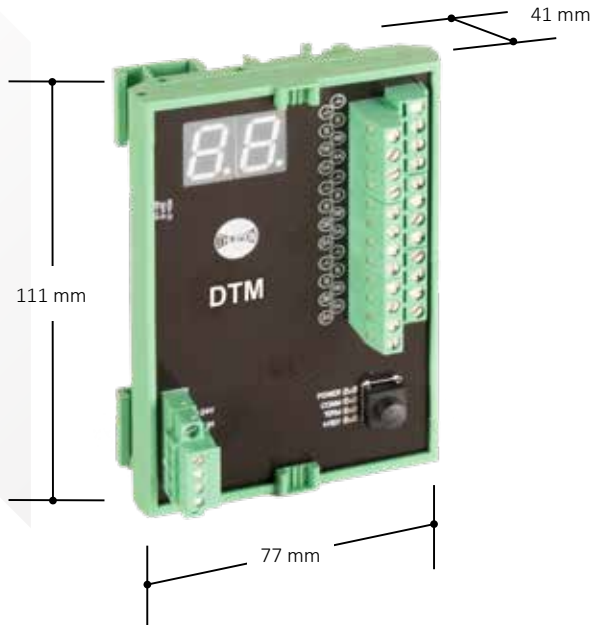

DTM PRODUCT FEATURES

- Up to six RTD sensors that can be independently addressed to one or more heat trace circuits
- DIN rail mountable
- Conformal coated printed circuit board for use in panels located in indoor and outdoor environments

DTM COMPONENT SPECIFICATIONS

Storage ambient temp. range..... -40°C to 105°C
 Operating ambient temp. range..... -40°C to 100°C¹
 Terminal connections..... up to 2.5 mm²
 Maximum RTD capacity 6

1. For designs that allow operation in ambient conditions below -40°C contact Thermon..

DTM CONNECTION DIAGRAM

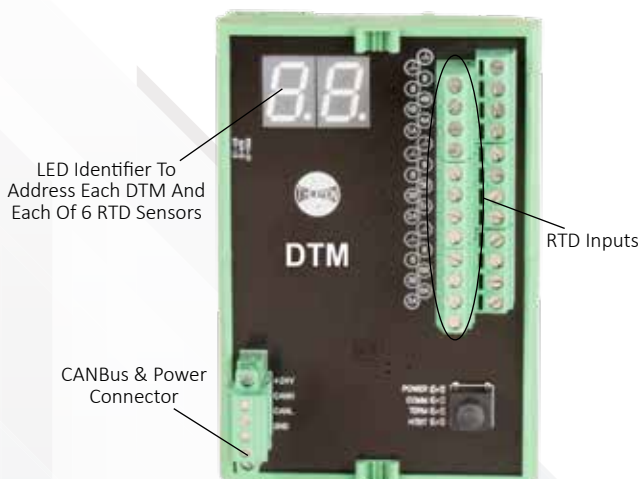

IOM (INPUT OUTPUT MODULE)

The IOM is a DIN rail mountable input/output module with 6 individually configurable input/output channels and one dedicated system fault alarm output. Outputs may be configured to signal a variety of conditions such as trips, low temperature alarms, ground/earth leakage alarms, etc. Inputs may be used to trigger a variety of events such as load shed or forcing on circuits.

IOM DIMENSIONAL DATA

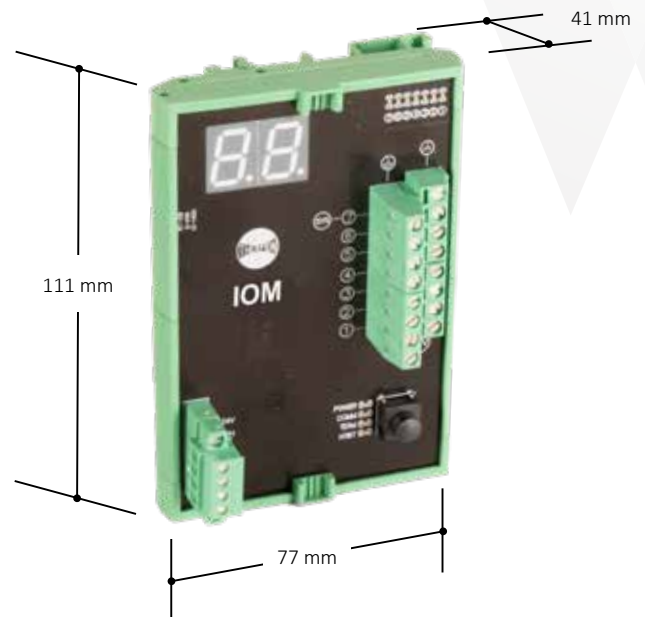

IOM PRODUCT FEATURES

- Operates in a wide range of ambient conditions
- DIN rail mountable
- Conformal coated printed circuit board for use in panels located in indoor and outdoor environments

IOM COMPONENT SPECIFICATIONS

Storage ambient temp. range..... -40°C to 105°C
 Operating ambient temp. range..... -40°C to 100°C
 Terminal connections..... up to 2.5 mm²

IOM CONNECTION DIAGRAM

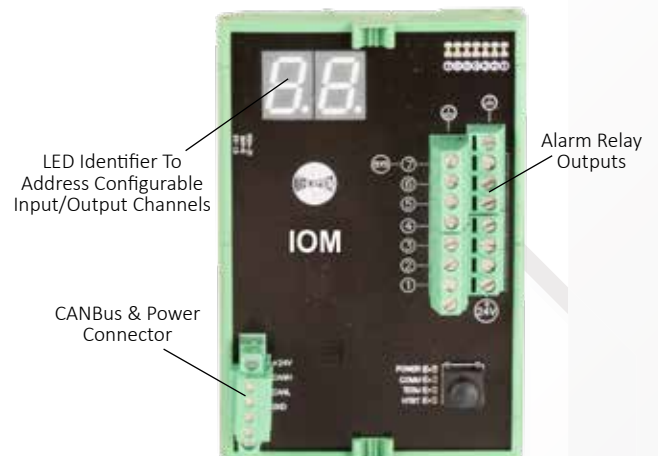

TRACENET COMMAND

Genesis Systems communicate via Ethernet to the Thermon TraceNet Command electric tracing circuit monitoring software. TraceNet Command provides centralized electric tracing information for all panels in a facility, such as:

- Heat tracing circuit status
- Temperatures, heater operating and earth/ground current alarm/trip events
- Event history
- Data trending
- Maintenance and troubleshooting guidance

TraceNet Command also gives the operator the ability on all panels from a single location to:

- Change set points as well as alarm and trip values
- Reconfigure system control parameters
- Provide heat tracing management reports
- Load shed circuits on a priority level basis



DCS (DISTRIBUTED CONTROL SYSTEMS) COMMUNICATIONS

Genesis Systems communicate via Ethernet to the plant DCS. The same operating data and control capabilities that are available through TraceNet Command are also accessible in the plant control room at the DCS.

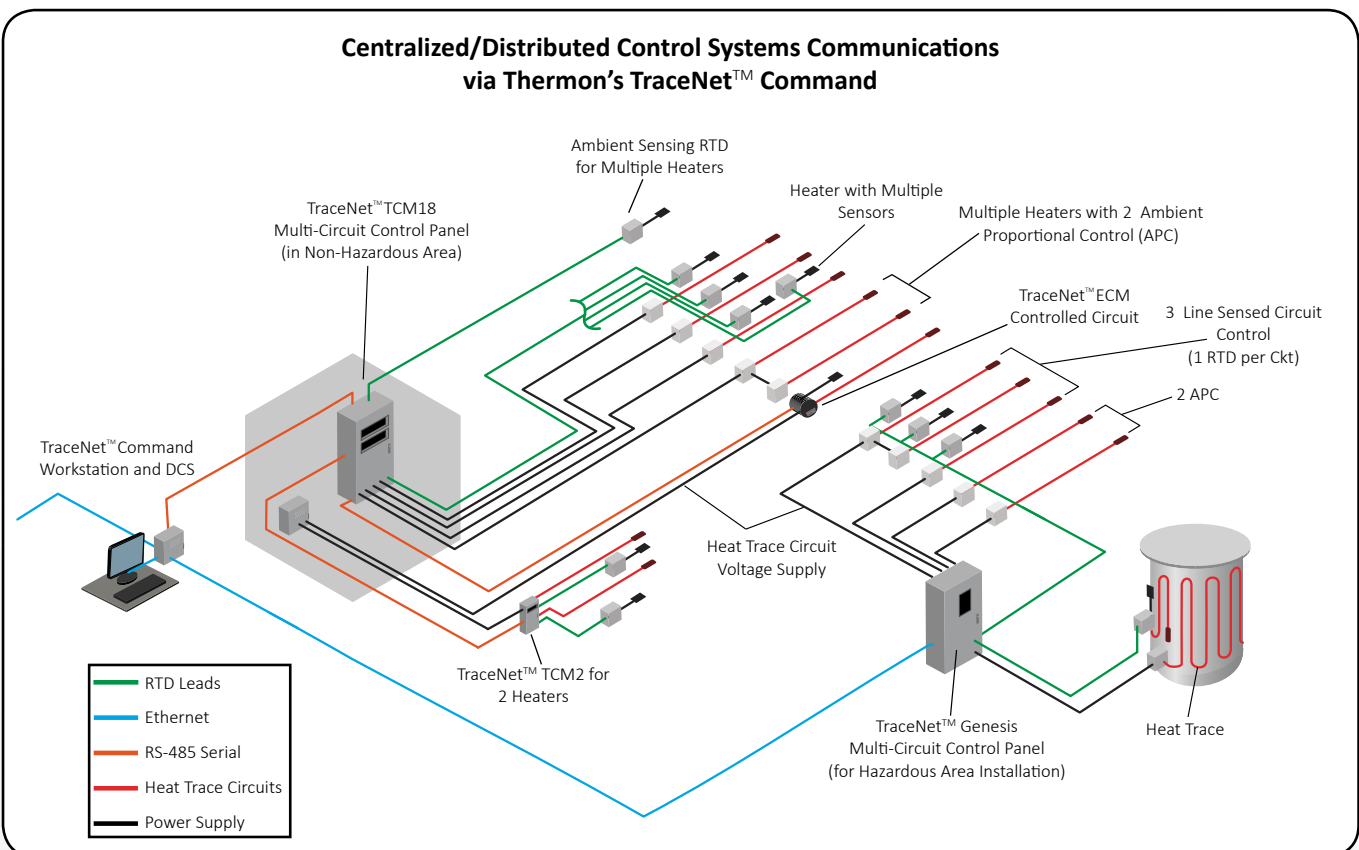

PRODUCT REFERENCE LEGEND

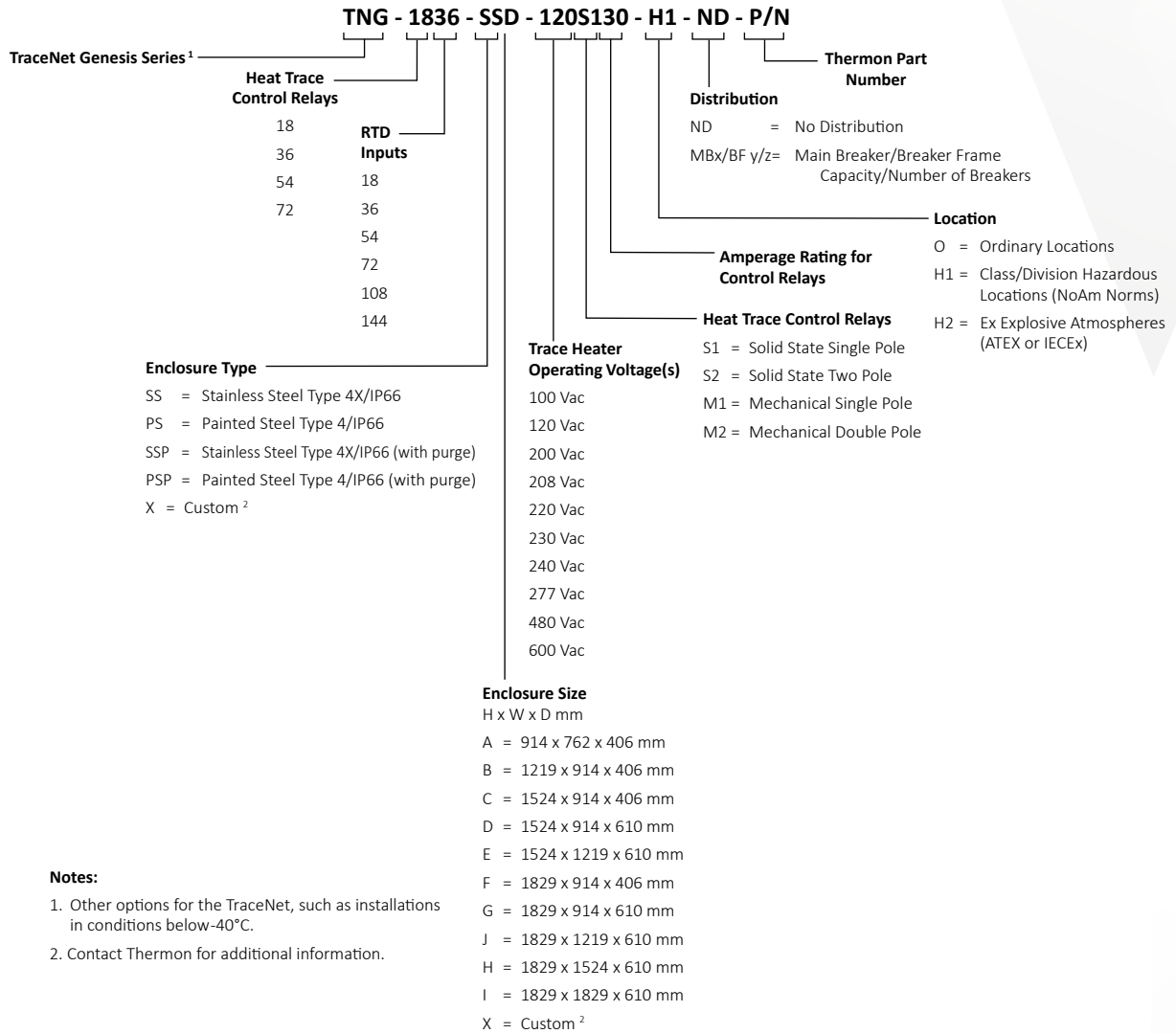



Corporate Headquarters: 100 Thermon Dr • PO Box 609 San Marcos, TX 78667-0609 • Phone: 512-396-5801 • 1-800-820-4328
For the Thermon office nearest you visit us at . . . www.thermon.com

Form TEP0212U-0718 © Thermon, Inc. • Printed in U.S.A. • Information subject to change.

TRACENET™ GENESIS

CONTROL AND MONITORING SYSTEM

SPECIFICATION GUIDE

